

REV.	NOTES	DATE
A	RELEASED	2017/07/07

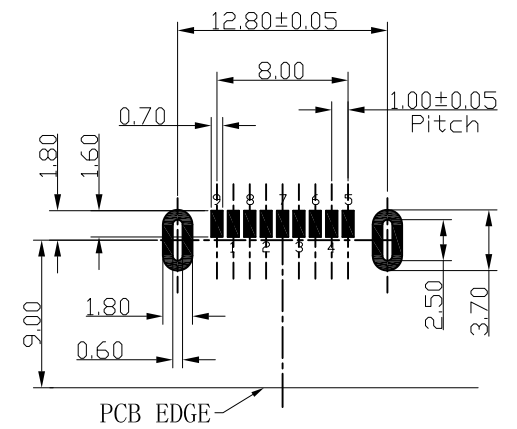
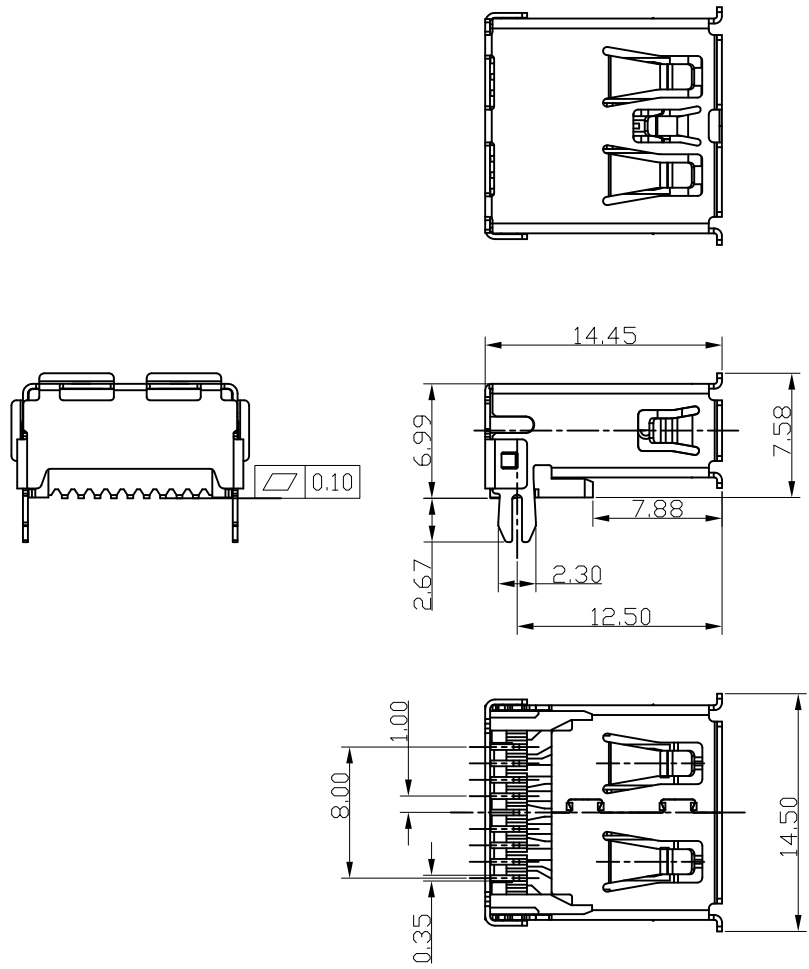

- NOTE:
- MATERIAL:
 - INSULATOR: HIGH TEMPERATURE PLASTIC
 - CONTACT: BRONZE,
 - SHELL: BRASS,
 - ELECTRICAL CHARACTERISTICS:
 - CONTACT RESISTANCE: 30mΩ MAXIMUM
 - CONTACT CURRENT RATING: 1.5A
 - DIELECTRIC WITHSTANDING VOLTAGE: 100 V AC R. M. S.
 - INSULATION RESISTANCE 100 MEGOHMS MIN
 - OPERATING TEMPERATURE: -40° C ~ 85° C
 - MECHANICAL CHARACTERISTICS:
 - MATING FORCE: 3.57kgf MAX
 - UNMATED FORCE: 0.82kgf MIN AFTER TEST
 - DURABILITY MANDATORY: 1, 500 CYCLES
 - Salt Spray: 24 hours

3	外壳	BRASS	镀镍40u"
2	端子	C2680	接触点 镀金15u" 焊脚 镀锡40u"
1	塑胶	LCP+30% G F	蓝色 UL94V-0
NO.	PART NAME	MATERIAL	DESCRIPTION

單位(UNIT)	東莞翊豐精密五金有限公司		
數量(QTY)	N/A	圖名(NAME)	
材料(MTL)	SEE NOTE	USB 3.0 AF SMT直腳 RoHS	
處理(FINISH)	SEE NOTE	料號(PART NUMBER)	AAUS-U322-0709
繪圖(DRAW)		圖號(DRAW NUMBER)	
設計(DE'N)		圖檔(FILE NAME .DWG)	
審核(CH'K)		比例(SCALE)	1/1
核准(APP'D)		圖紙(SIZE)	A4
		頁次(SHEET)	1
		版次(REV.)	A

DIMENSIONS TOLERANCE METRIC	
X	:±0.3
X.X	:±0.2
X.XX	:±0.1
X.XXX	:±0.05
ANGLES	
X	:±1°
X.X	:±0.5°