

REV.	NOTES	DATE
A	RELEASED	2017/09/06

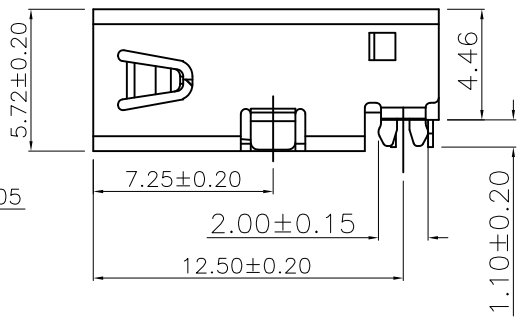
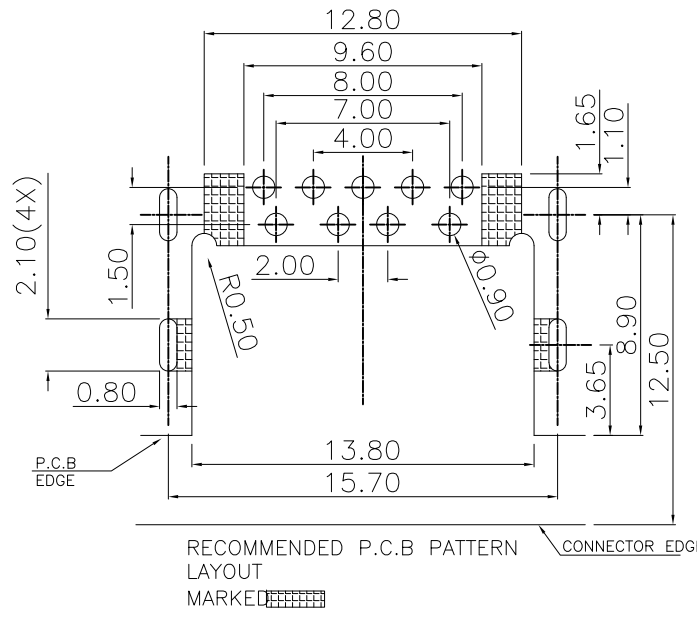
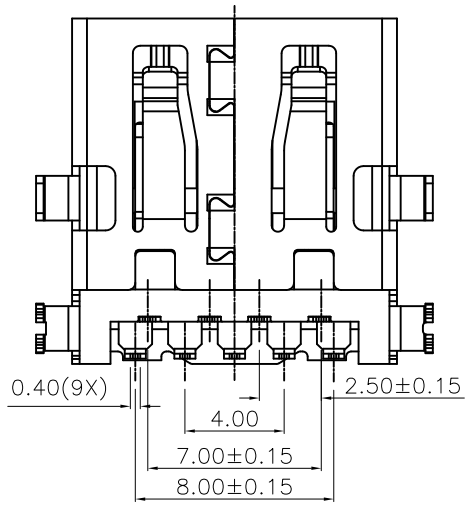
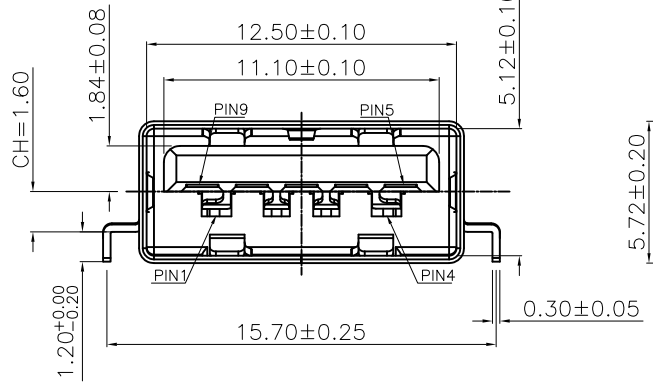
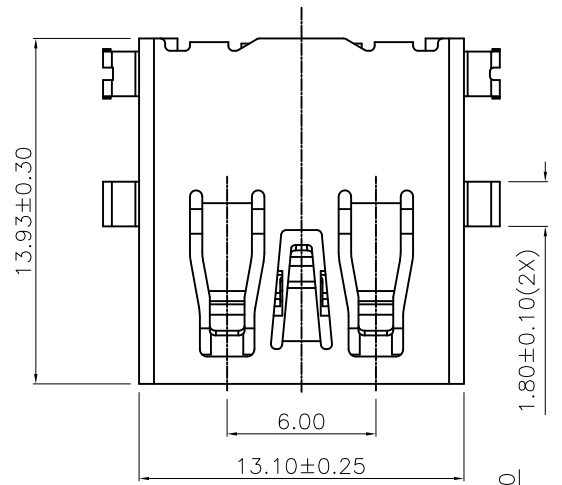

- NOTE:
- MATERIAL:
 - INSULATOR: LCP UL 94 V-0 BLUE;
 - CONTACT: COPPER ALLOY(T=0.2mm)
 - SHELL: SUS201(T=0.30mm)
 - ELECTRICAL CHARACTERISTICS:
 - CONTACT RESISTANCE: 30mΩ MAX.
 - CONTACT CURRENT RATING: 1.5A
 - DIELECTRIC WITHSTANDING VOLTAGE: 500 V R.M.S.
 - INSULATION RESISTANCE 100 MEGOHMS M
 - OPERATING TEMPERATURE: -55°C~85°C
 - RATE VOLTAGE: 30V DC
 - MECHANICAL CHARACTERISTICS:
 - MATING FORCE: 10 N Min INITIAL; 8 N Min AFTER TEST
 - UNMATED FORCE: 35 N Max
 - DURABILITY: 5,000 CYCLES
 - PLATING
 - TERMINAL CONTACT: GOLD PLATING ALL OVER
30u" MIN NICKEL AND 60u" MIN Matte Tin
NICKEL IN SOLDER AREA (SEE TAB)
 - SHELL: 30u" MIN. NICKEL ALL OVER

DIMENSIONS TOLERANCE METRIC

X : ±0.5
 X.X : ±0.30
 X.XX : ±0.20

ANGLES
 X : ±1°
 X.X : ±0.5°

單位(UNITS)	mm	東莞翊豐精密五金有限公司							
數量(QT'Y)	N/A								
材料(MT'L)	SEE NOTE								
處理(FINISH)	SEE NOTE								
繪圖(DRAW)		圖名(NAME) USB 3.0-A母座(DIP)正向 CH=1.6MM							
設計(DE'N)		料號(PART NUMBER)	AAUS+US09P-N280R						
審核(CH'K)		圖號(DRAW NUMBER)							
核准(APP'D)		圖檔(FILE NAME .DWG)							
		比例(SCALE)	1/1	圖紙(SIZE)	A4	頁次(SHEET)	1	版次(REV.)	A