

REV.	NOTES	DATE
A	RELEASED	2017/07/19
B	B:增加噴碼	2017/09/26

Date Code
P:生产地-2
Y:年份-7:17年
WW:周数
D:星期(1-7) $\triangle B$

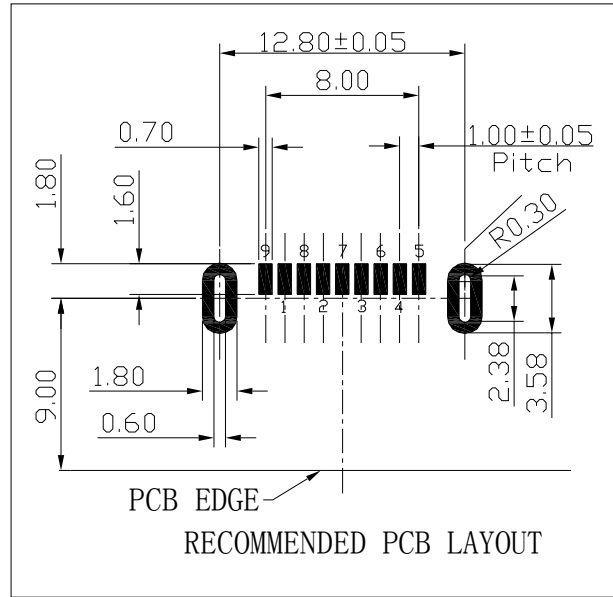

- NOTE:
- MATERIAL:
 - INSULATOR: LCP+30%GF UL 94V-0 BLUE 300C
 - CONTACT: C2680
 - SHELL: BRASS
 - ELECTRICAL CHARACTERISTICS:
 - CONTACT RESISTANCE: 30m Ω MAXIMUM
 - CONTACT CURRENT RATING: 1.5A
 - DIELECTRIC WITHSTANDING VOLTAGE: 100 V AC R. M. S.
 - INSULATION RESISTANCE 100 MEGOHMS MIN
 - OPERATING TEMPERATURE: -55° C ~ +85° C
 - MECHANICAL CHARACTERISTICS:
 - MATING FORCE: 3.57kgf MAX
 - UNMATED FORCE: 0.82kgf MIN AFTER TEST
 - DURABILITY MANDATORY: 5,000 CYCLES
 - PLATING
 - TERMINAL:
 - 40 μ MIN NICKEL ALL OVER
 - 40 μ MIN Tin ON SOLDER AREA
 - 1 μ MIN Au ON CONTACT AREA
 - SHELL: 40 μ MIN. NICEL ALL OVER

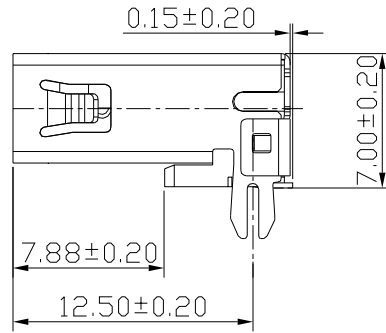
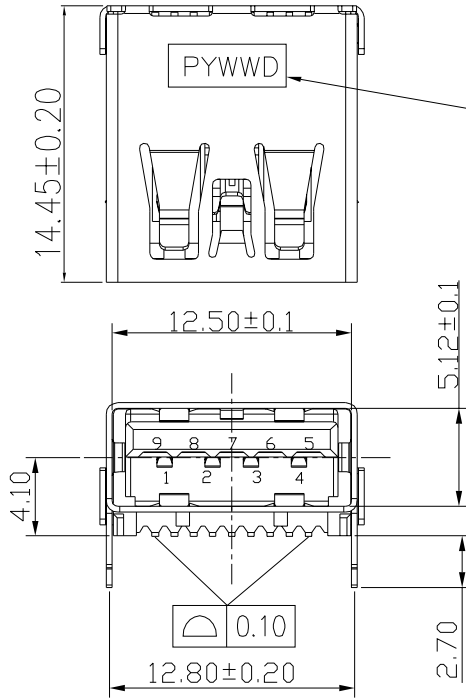
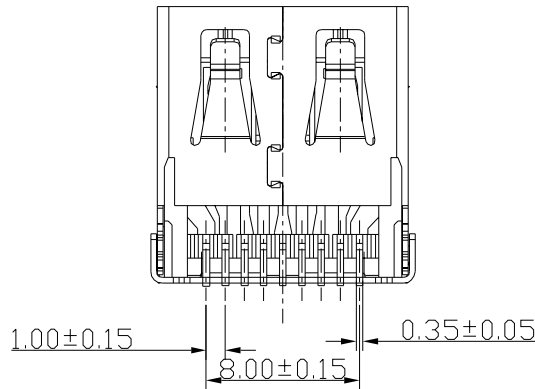

DIMENSIONS TOLERANCE METRIC	
X	:±0.5
X.X	:±0.30
X.XX	:±0.20
ANGLES	
X	:±1°
X.X	:±0.5°

單位(UNITS)	mm	東莞翊豐精密五金有限公司							
數量(QTY)	N/A								
材料(MTL)	SEE NOTE								
處理(FINISH)	SEE NOTE								
繪圖(DRAW)		圖名(NAME) USB 3.0 AF 板上SMT型鱼叉脚 短体 L=14.45							
設計(DE'N)		料號(PART NUMBER)		AAUS+U322-023X					
		圖號(DRAW NUMBER)		RAAUSU322023					
審核(CH'K)		圖檔(FILE NAME .DWG)							
核准(APP'D)		比例(SCALE)	1:1	圖紙(SIZE)	A4	頁次(SHEET)	1/2	版次(REV.)	B