

Halogen-free

REV.	NOTES	DATE
A	NEW	2015/12/11
B	修改外觀增加管控尺寸 \triangle	2016/10/27
C	減膠 \triangle	2016/12/27
D	增加cpk尺寸 \triangle	2017/05/10

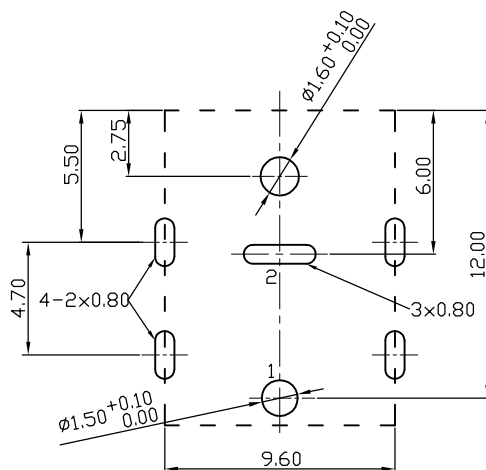
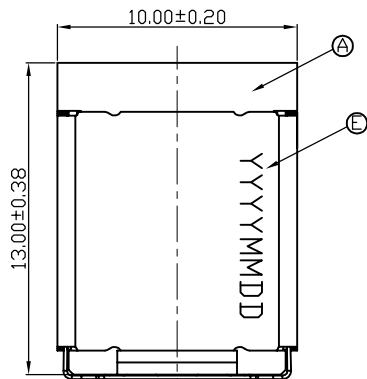

RECOMMENDED PCB LAYOUT
TOP VIEW (TOLERANCE: ±0.05)

SPECIFICATIONS:

- INSERTION FORCE: 3.0KG MAX. WITHDRAWAL FORCE: 1.0KG~3.0KG
- INSULATION RESISTANCE BETWEEN ANY ADJACENT TERMINALS SHALL NOT BE LESS THAN 100 MEGOHMS BY 500 VOLTS MEGGER
- JACK SHALL WITHSTAND 250 VOLTS BETWEEN ANY ADJACENT TERMINAL FOR ONE MINUTE.
- CONTACT RESISTANCE SHALL NOT EXCEED 30m Ω
- JACK SHALL WITHSTAND 5000 CYCLES OF INSERTION AND WITHDRAWAL WITH TESTING PLUG, AND CONTACT RESISTANCE SHALL NOT EXCEED 30m Ω
- MEASURING CONDITION: TEMPERATURE: FROM 5°C TO 35°C RELATIVE HUMIDITY: FROM 40% TO 85%.
- ENVIRONMENTAL SPECIFICATIONS:
 - HUMIDITY TEST: HUMIDITY 90% TO 95% TEMPERATURE 40°C ± 2°C FOR 96 HOURS
 - HEAT TEST: TEMPERATURE 70°C ± 2°C (HUMIDITY BELOW 50%) FOR 96 HOURS.
 - COLD TEST: TEMPERATURE -40°C ± 2°C FOR 96 HOURS.
- PACKAGING: TRAY

9.帶*為重點管控尺寸.

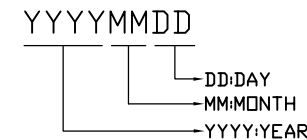
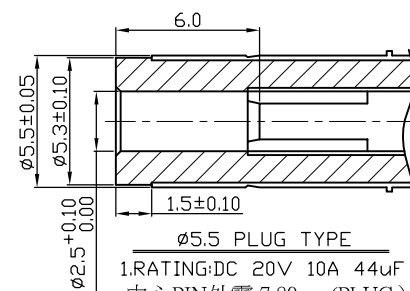
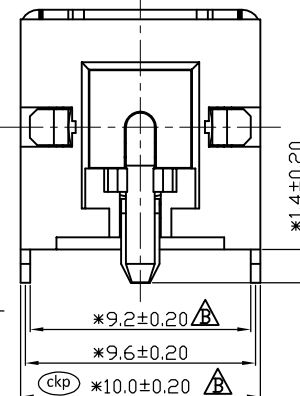
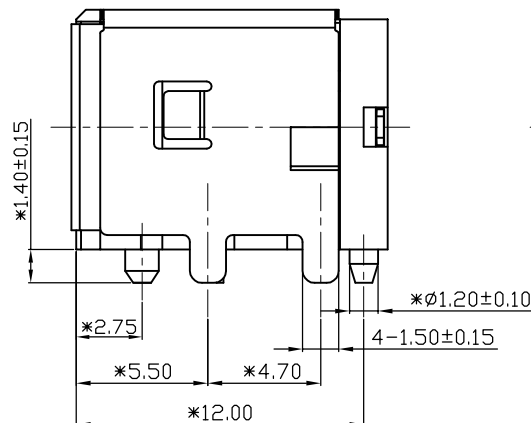
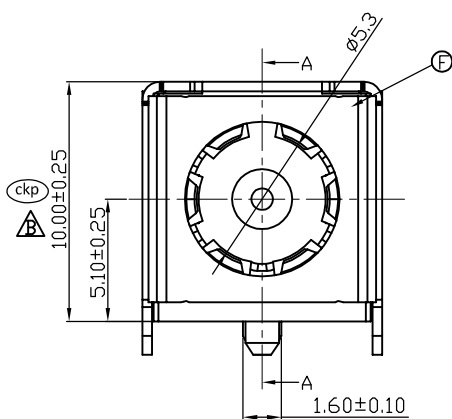

Ø5.5 PLUG TYPE

1. RATING: DC 20V 10A 44uF
中心PIN外露 7.80mm (PLUG)

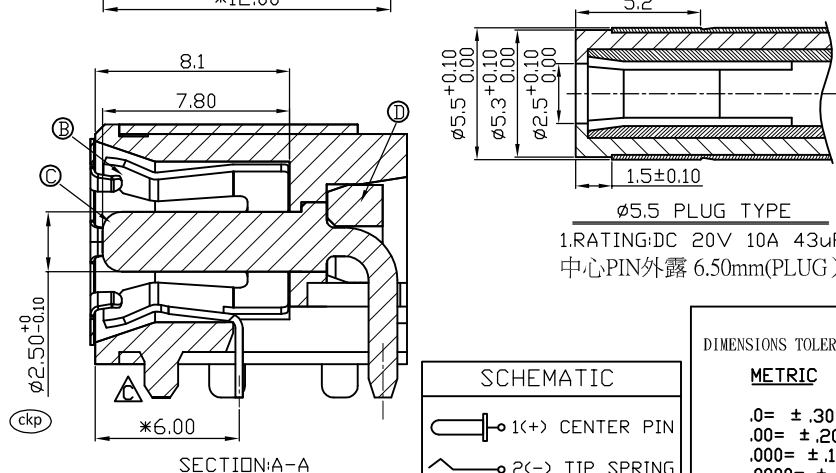
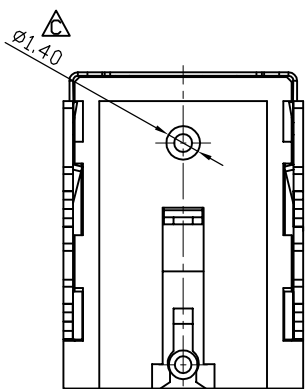

Ø5.5 PLUG TYPE

1. RATING: DC 20V 10A 43uF
中心PIN外露 6.50mm (PLUG)

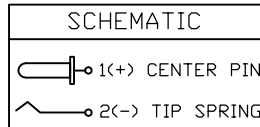

DIMENSIONS TOLERANCE

METRIC
.0 = ± 0.30
.00 = ± 0.20
.000 = ± 0.10
.0000 = ± .05
ANG. = ± 2°

NO.	DESCRIPTION	QTY	MATERIAL	PLATING&COLOR
F	GROUND	1	STAINLESS 0.15t	N/A
E	SHELL	1	SPCC-SD 0.40t	Nickel 60u" Overall
D	STOPPER	1	PA9T, UL 94V-0 Halogen-free	BLACK
C	PIN	1	BRASS	Ag: 20u" Min On Contact Area Cu: 60u" Min On Solder Ni: 60u"
B	SPRING	1	PHOSPHOR BRONZE 0.30t	Sn: 60u" Min On Contact Area Cu: 60u" Min On Solder Ni: 60u"
A	HOUSING	1	PA9T, UL 94V-0 Halogen-free	BLACK

單位 (UNITS)	mm
數量 (QTY)	N/A
材料 (MATERIAL)	SEE NOTE
處理 (FINISH)	SEE NOTE

東莞翊豐精密五金有限公司

圖名 (NAME)
DC POWER JACK 中心PIN 7.80mm 鐵殼鍍鎳 無窗

料號 (PART NUMBER) APJ+6D44+081

圖號 (DRAW NUMBER) RAPJ6D44081

圖檔 (FILE NAME .DWG)

繪圖 (DRAW)	
設計 (DE'N)	
審校 (CH'K)	
核准 (APP'D)	

比例 (SCALE)	圖紙 (SIZE)	頁次 (SHEET)	版次 (REV.)
1/1	A4	1/1	D