

REV.	NOTES	DATE
A	RELEASED	2018/03/22
B	修改圖面	2018/06/05
C	產品尺寸調整	2018/06/05
D	修改新的公座搭配使用	2019/04/17

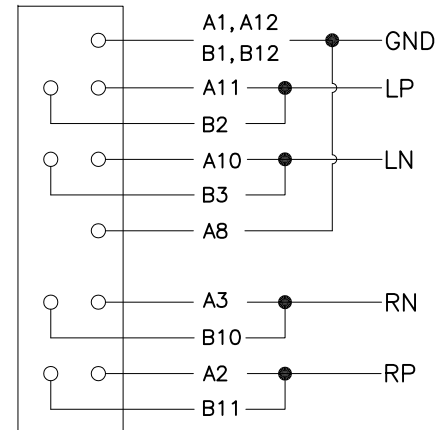
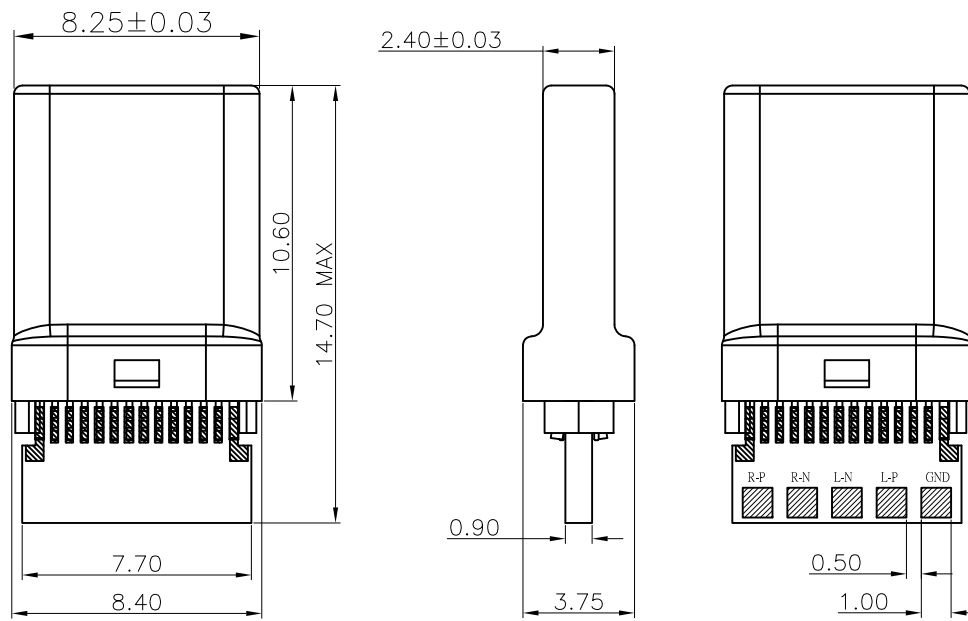
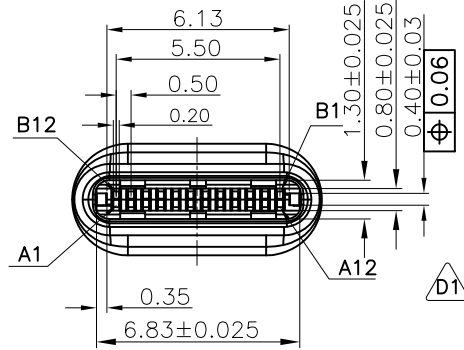

SPECIFICATION

1. CURRENT RATING : 5.0 A.
2. DIELECTRIC WITHSTANDING VOLTAGE : 100V AC R.M.S. FOR ONE MINUTE.
3. INSULATION RESISTANCE : 100M OHMS MIN.
4. CONTACT RESISTANCE : 40m OHMS MAX.
5. MATING FORCE : 5~20N MAX.
6. UNMATING FORCE : 8~20N MIN.
7. DURABILITY : 10,000 CYCLES.
8. OPERATING TEMPERATURE : -30°C TO +80°C.

A12	A11	A10	A9	A8	A7	A6	A5	A4	A3	A2	A1
GND	RX2+	RX2-	Vbus	SBU1	D-	D+	CC	Vbus	TX1-	TX1+	GND
GND	TX2+	TX2-	Vbus	Vconn			SBU2	Vbus	RX1-	RX1+	GND
B1	B2	B3	B4	B5	B6	B7	B8	B9	B10	B11	B12

ITEM	COMPONENT NAME	MATERIALS	FINISH/SPEC
4	GRN SPRING	STAINLESS STEEL	
3	TERMINAL	C7025	GOLD PLATED ON CONTACT AREA,TIN PLATED ON SOLDER TAILS.
2	SHELL&LATCH	STAINLESS STEEL	NICKEL PLATED OVERALL.
1	HOUSING	THERMOPLASTIC	(UL94V-0),BLACK

DIMENSIONS TOLERANCE METRIC

X : ±0.5
X.X : ±0.30
X.XX : ±0.20

ANGLES
X : ±1°
X.X : ±0.5°

單位(UNITS)	mm	東莞翊豐精密五金有限公司			
數量(QT'Y)	N/A				
材料(MT'L)	SEE NOTE				
處理(FINISH)	SEE NOTE	圖名(NAME)			
繪圖(DRAW)		USB Type C 公头 L=14.70 夾板式塑膠有限位 (拉伸殼)			
設計(DE'N)		料號(PART NUMBER)	AAUS+TC24P-M009		
審校(CH'K)		圖號(DRAW NUMBER)			
核准(APP'D)		圖檔(FILE NAME .DWG)			
		比例(SCALE)	1:1	圖紙(SIZE)	A4
		頁次(SHEET)	1/2	版次(REV.)	D