

REV.	NOTES	DATE
A	RELEASED	2019/08/22

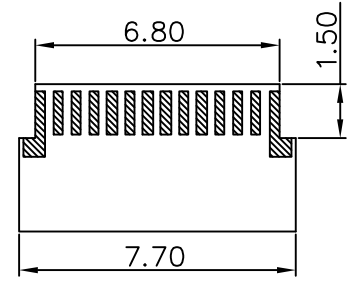

RECOMMENDED P.C.B LAYOUT
ALL TOLERANCE ±0.05mm

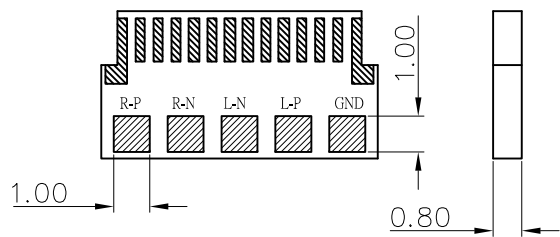
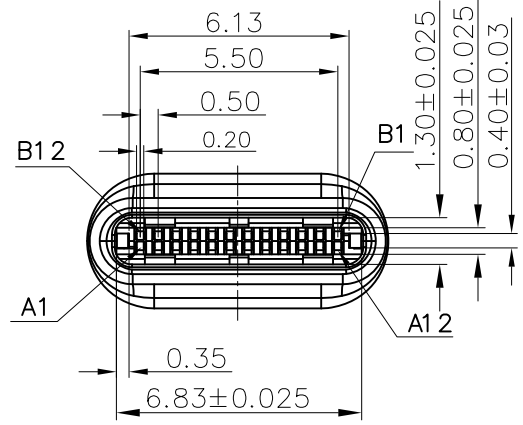
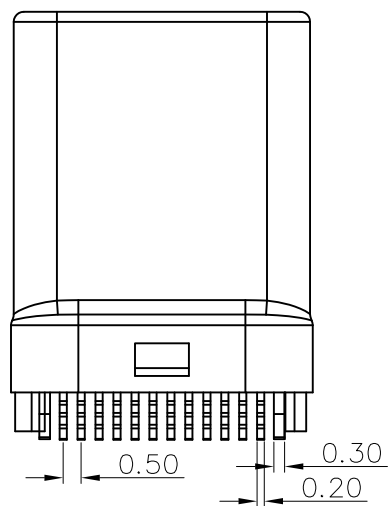
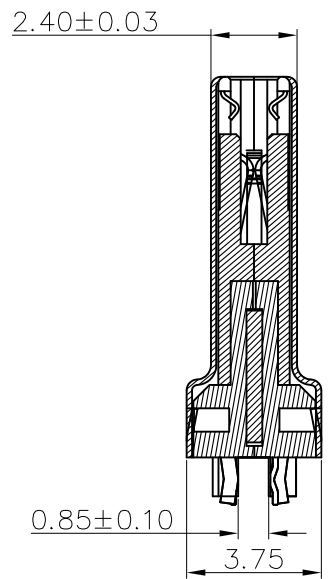
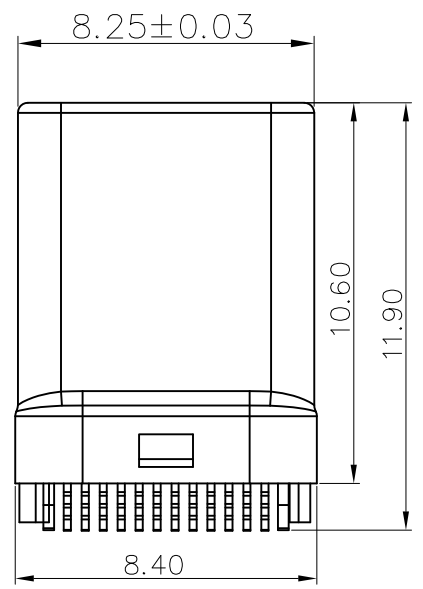

SPECIFICATION

- CURRENT RATING : 5.0 A.
- DIELECTRIC WITHSTANDING VOLTAGE : 100V AC R.M.S. FOR ONE MINUTE.
- INSULATION RESISTANCE : 100M OHMS MIN.
- CONTACT RESISTANCE : 40m OHMS MAX.
- MATING FORCE : 5~20N MAX.
- UNMATING FORCE : 8~20N MIN.
- DURABILITY : 10,000 CYCLES.
- OPERATING TEMPERATURE : -30°C TO +80°C.

A12	A11	A10	A9	A8	A7	A6	A5	A4	A3	A2	A1
GND	RX2+	RX2-	Vbus	SBU1	D-	D+	CC	Vbus	TX1-	TX1+	GND
GND	TX2+	TX2-	Vbus	Vconn			SBU2	Vbus	RX1-	RX1+	GND
B1	B2	B3	B4	B5	B6	B7	B8	B9	B10	B11	B12

3	TERMINAL	C7025	GOLD PLATED ON CONTACT AREA, TIN PLATED ON SOLDER TAILS.
2	SHELL & LATCH	STAINLESS STEEL	NICKEL PLATED OVERALL.
1	HOUSING	THERMOPLASTIC	(UL94V-0), BLACK
ITEM	COMPONENT NAME	MATERIALS	FINISH/SPEC

DIMENSIONS TOLERANCE METRIC
X : ±0.5
X.X : ±0.30
X.XX : ±0.20
ANGLES
X : ±1°
X.X : ±0.5°

單位(UNITS)	mm
數量(QTY)	N/A
材料(MTL)	SEE NOTE
處理(FINISH)	SEE NOTE

東莞翊豐精密五金有限公司				
圖名(NAME)				
USB Type C 空公头 L=11.90 夾板式塑膠有限位 (拉伸殼)				
料號(PART NUMBER)		AAUS+TC24P-M1190		
圖號(DRAW NUMBER)				
圖檔(FILE NAME .DWG)				
比例(SCALE)	1:1	圖紙(SIZE)	A4	頁次(SHEET)
				1/2
核准(APP'D)		版次(REV.)	A	