

REV.	NOTES	DATE
A	RELEASED	2023/03/28
B	依客戶要求修改產品11.1尺寸公差為+/-0.10	2024/04/17
C	依客戶要求增加說明0.6kgf~2.0kgf(AFTER 10000 CYCLES);	2024/05/06
D	依客戶要求增加說明	2024/07/02

NOTE:

1.MATERIAL SPECIFICATION:

- 1.HOUSING&PICKUP COVER:LCP,UL94 V-0.
- 2.CONTACTS: COPPER ALLOY(C7025)
- 3.LATCH: STAINLESS STEEL(SUS301)
- 4.SPRING: STAINLESS STEEL(SUS304)
- 4.FRONT SHELL: STAINLESS STEEL(SUS304)

2.PLATING SPECIFICATION:

2-1.CONTACTS:

Ni 50u" MIN. UNDER PLATED OVER ALL.  
 Au PLATED ON THE FUNCTIONAL AREA OF CONTACT.  
 (GOLD PLATING THICKNESS FOLLOW THE P/N)  
 PLATING SPECIFICATIONS OF THE SOLDER AREA FOLLOW THE P/N

2-2.FRONT SHELL:

Ni 30u" MIN. UNDER PLATED OVER ALL.

2-3.LATCH:

Ni 50u" MIN. UNDER PLATED OVER ALL.  
 80u" MIN. TIN PLATED ON SOLDER AREA.

2-4.SPRING:

CLEAR ONLY

3.MECHANICAL PERFORMANCE,

- 3-1.INSERTION FORCE: 0.5~2.0kgf(Initial and after 10000 CYCLES).
- 3-2.WITHDRAWAL FORCE: 0.8kgf~2.0kgf(Initial),0.6kgf~2.0kgf(AFTER 10000 CYCLES);
- 3-3.DURABILITY: 10000 CYCLES.

4.ELECTRICAL PERFORMANCE,

- 4-1. CURRENT RATING:3.0A  
VOLTAGE RATING:5.0V
- 4-2. LLCR:  
VBUS & GND PINS AND OTHER PINS: 40mΩ/PIN MAX.  
SHIELD: 50mΩ/MAX.  
LLCR MAX. CHANGE OF ALL PINS: 10mΩ.
- 4-3.INSULATION RESISTANCE: 100MΩ MIN
- 4-4.DIELECTRIC WITHSTAND VOLTAGE,AC 100V FOR 1 MINUTE.

5. ENVIRONMENTAL PERFORMANCE:

OPERATING TEMPERATURE: -25°C~+85°C.

6.IR REFLOW:

THE PEAK TEMPERATURE ON THE BOARD SHALL  
 BE MAINTAINED FOR 10 SECONDS AT 260°C.

- 7.THE USB-C PLUG & ITS CONTACTS SHALL BE FREE OF ANY FOREIGN,  
 DEBRIS AND LOOSE BURRS MATERIAL;

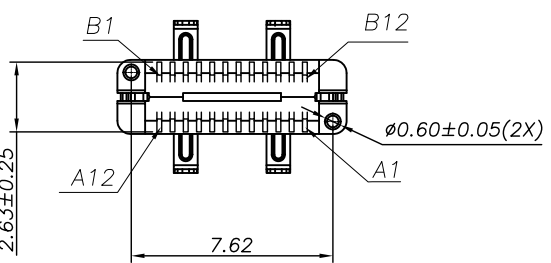
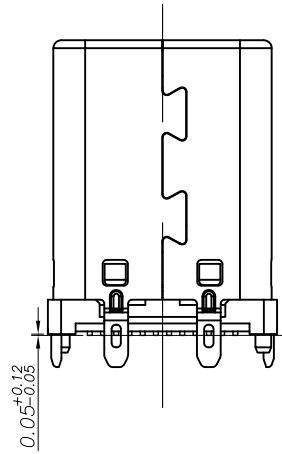
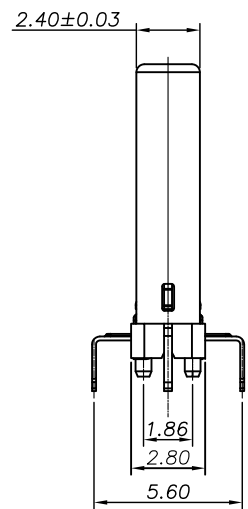
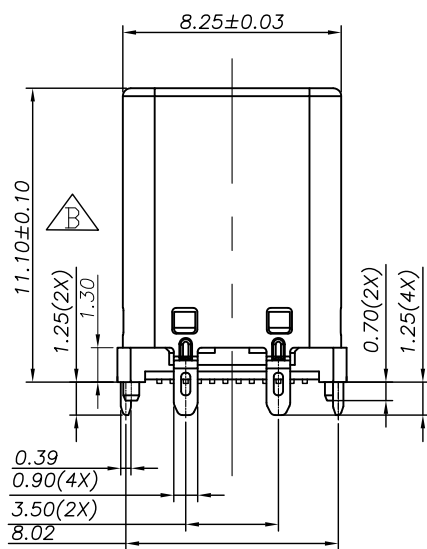
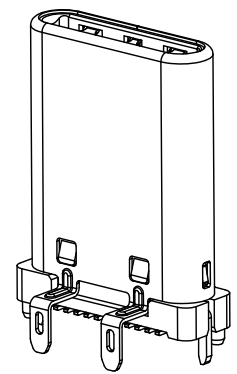
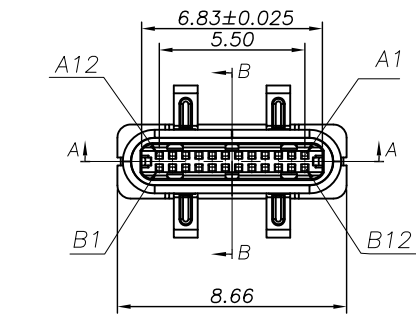

TABLE 1

ITEM	P/N	HOUSING COLOR	CONTACTS	
			FUNCTIONAL AREA	SOLDER AREA
1	AAUS+TC24P+HSD129	BLACK	Au:1u"	Sn 80u"

DIMENSIONS TOLERANCE METRIC	
X	±0.3
X.X	±0.25
X.XX	±0.2
X.XXX	±0.05
ANGLES	
X	±1'
X.X	±0.5°

單位(UNITS)	mm
數量(QTY)	N/A
材料(MTL)	SEE NOTE
處理(FINISH)	SEE NOTE

東莞翊豐精密五金有限公司

圖名(NAME)  
 USB TYPE C PLUG 24PIN 直立式SMT 四支腳 (L=11.1MM) HF

料號(PART NUMBER) AAUS+TC24P+HSD129  
 圖號(DRAW NUMBER)

圖檔(FILE NAME .DWG)

核准(APP'D)	比例(SCALE) 1/1	圖紙(SIZE) A4	頁次(SHEET) 1/3	版次(REV.) D
-----------	---------------	-------------	---------------	------------